



Leaded Oscillator, OCXO
Metal Package, Full Size DIP



I401 Series

Product Features:

Available in Both Sinewave and
HCMOS/TTL Compatible outputs
RoHS Compliant

Applications:

Telecommunications
Data Communications
Instrumentation
Test and Measurement

Frequency	1.000 MHz to 50.000 MHz
Output Level HC-MOS TTL Sine	'0' = 0.1 Vcc Max., '1' = 4.5 VDC Min. '0' = 0.4 VDC Max., '1' = 2.4 VDC Min. +4dBm, ±3dBm
Duty Cycle	50% ±10% or ±5% See Table
Rise / Fall Time	10 nS Max.
Output Load HC-MOS TTL Sine	See Output Table 15 pF 50 ohms
Frequency Stability	See Frequency Stability Table
Supply Voltage	See Supply Voltage Table
Current (Warm Up) Current @ 25° C	400 mA @ 5 VDC, 170 mA @ 12 VDC Max. 120 mA @ 5 VDC, 60 mA @ 12 VDC Typ.
Control Voltage	2.5 VDC ±2.0 VDC, ±8 ppm Min.
Slope	Positive
Operating	See Operating Temperature Table in Part Number Guide
Storage	-55° C to +125° C

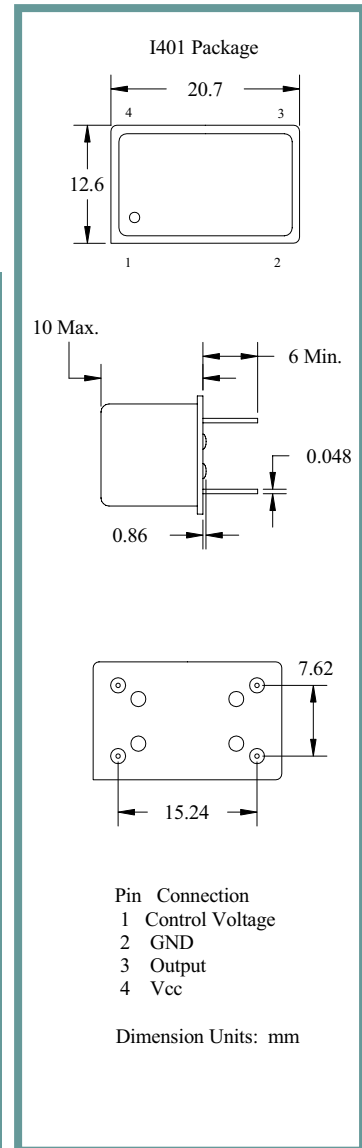

Part Number Guide		Sample Part Number: I401-5151YV-20.000 MHz					
Package	Input Voltage	Operating Temperature	Symmetry (Duty Cycle)	Output	Frequency Stability (in ppm)	Voltage Control	Frequency
I401 -	5 = 5.0 V	7 = 0° C to +50° C	5 = 45 / 55 Max.	1 = 10 TTL / 15pF HC-MOS	N = ±1.0	V = Controlled	-20.000 MHz
	9 = 12 V	1 = 0° C to +70° C	6 = 40 / 60 Max.	3 = 15pF HC-MOS	Y = ±0.5	F = Fixed	
		6 = -10° C to +75° C		6 = 30pF	1 = ±0.25		
		3 = -20° C to +85° C		4 = AC-MOS	2 = ±0.1		
				A = Sine	3 = ±0.05*		

NOTE: A 0.01 µF bypass capacitor is recommended between Vcc (pin 4) and GND (pin 2) to minimize power supply noise.
* Frequency, supply, and load related parameters.



Leaded Oscillator, OCXO
Metal Package, Full Size DIP



1401 Series

Pb Free Solder Reflow Profile:

Typical Application:

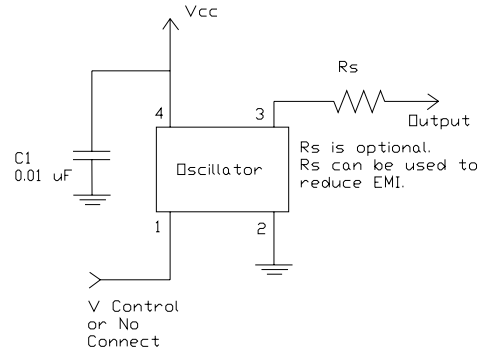
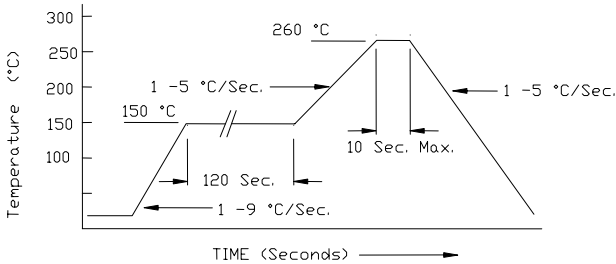

*Units are backward compatible with 240C reflow processes

Package Information:

MSL = N.A. (package does not contain plastic, storage life is unlimited under normal room conditions).
Termination = e1 (Sn / Cu / Ag over Ni over Kovar base metal).

Environmental Specifications

Thermal Shock	MIL-STD-883, Method 1011, Condition A
Moisture Resistance	MIL-STD-883, Method 1004
Mechanical Shock	MIL-STD-883, Method 2002, Condition B
Mechanical Vibration	MIL-STD-883, Method 2007, Condition A
Resistance to Soldering Heat	J-STD-020C, Table 5-2 Pb-free devices (except 2 cycles max)
Hazardous Substance	Pb-Free / RoHS / Green Compliant
Solderability	JESD22-B102-D Method 2 (Preconditioning E)
Terminal Strength	MIL-STD-883, Method 2004, Test Condition D
Gross Leak	MIL-STD-883, Method 1014, Condition C
Fine Leak	MIL-STD-883, Method 1014, Condition A2, R1=2x10 ⁻⁸ atm cc/s
Solvent Resistance	MIL-STD-202, Method 215

Marking

Line 1: ILSI and Date Code
Line 2: XXXXXX (Part Number detail = I401-XXXXXX-Freq.)
Line 2: Frequency