

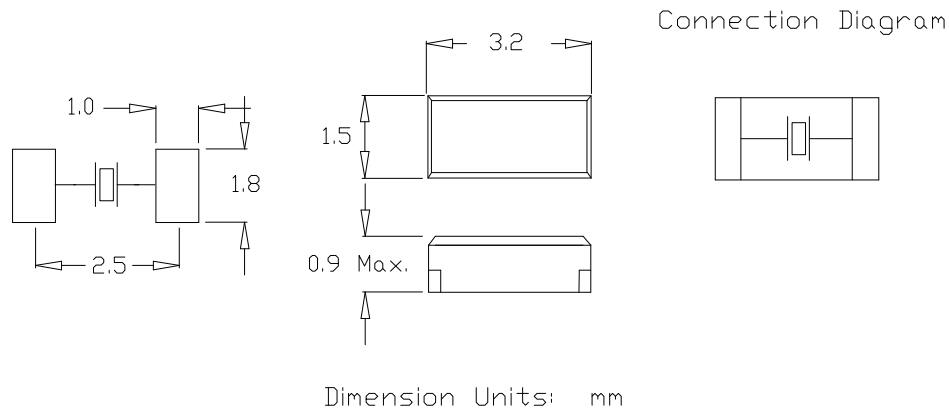

SMD Crystal, X cut
2 Pad Ceramic Package, 1.5 mm x 3.2 mm

IL3X Series

Frequency Range (KHz)	32.768 KHz
Equivalent Series Resistance (Ω)	65 K Max.
Shunt Capacitance (C0)	1.7 pF Typical
Frequency Tolerance	± 20 ppm Standard (see Appendix A for more options)
Frequency Stability over Temperature	X cut (see Appendix D, page 5 for information)
Frequency / Temperature Coefficients	-0.034 ppm / ° C Typical. Inflection point approx. 27° C
Load Capacitance	12.5 pF
Drive Level	1 uW Max.
Aging	± 5 ppm Max. / Year Standard
Temperature	
Operating	-40° C to +85° C Standard (see Appendix A for more options)
Storage	-40° C to +85° C Standard
Environmental / Tape and Reel	See Appendix B for Environmental information, Appendix C for Tape and Reel information
Package Information	MSL = N.A., Termination = e4



Part Number Guide		Sample Part Number: IL3X - HX5F12.5 - 32.768 KHz				
Package	Frequency Tolerance	Frequency Stability	Operating Temp.	Mode	Load Capacitance	Frequency
IL3X -	H = ± 20 ppm	X = X cut	5 = -40° C to +85° C	F = Fundamental	12.5 = 12.5 pF	- 32.768 KHz