



2 Lead Metal Package Crystal, 3 mm x 8 mm, 2 mm x 6 mm, 1 mm x 5 mm

38 / 26 / 15 Series

Product Features:

- Small Package Option
- Compatible with Leadfree Processing
- Low Cost

Applications:

- Real Time Clocks
- Metering
- Industrial Control
- Time Reference

Frequency	30 KHz to 192.000 KHz (15 package only available at 32.768 KHz)		
ESR (Equivalent Series Resistance) 30 KHz – 31.9 KHz 32 KHz – 39.9 KHz 40 KHz – 59.9 KHz 60 KHz – 99.9 KHz 100 KHz – 192 KHz	15 Package (32.768Khz Only) 40 KΩ Max.	26 Package 40 KΩ Max. 35 KΩ Max. 30 KΩ Max. 25 KΩ Max. 20 KΩ Max.	38 Package 30 KΩ Max. 30 KΩ Max. 30 KΩ Max. 25 KΩ Max. 20 KΩ Max.
Shunt Capacitance (C0)	0.8 pF to 1.7 pF Typical		
Frequency Tolerance @ 25° C	±20 ppm Standard (see Part Number Guide for more options)		
Frequency Stability over Temperature	Parabolic -0.034 ppm / ° C ² Typical. Inflection point approx. 27° C., See Table Below		
Crystal Cut	X cut		
Load Capacitance	12.5 pF Standard		
Drive Level	1 μW Max.		
Aging	±5 ppm Max. / Year Standard		
Temperature			
Operating	-40° C to +85° C Standard (see Part Number Guide for more options)		
Storage	-40° C to +85° C Standard		

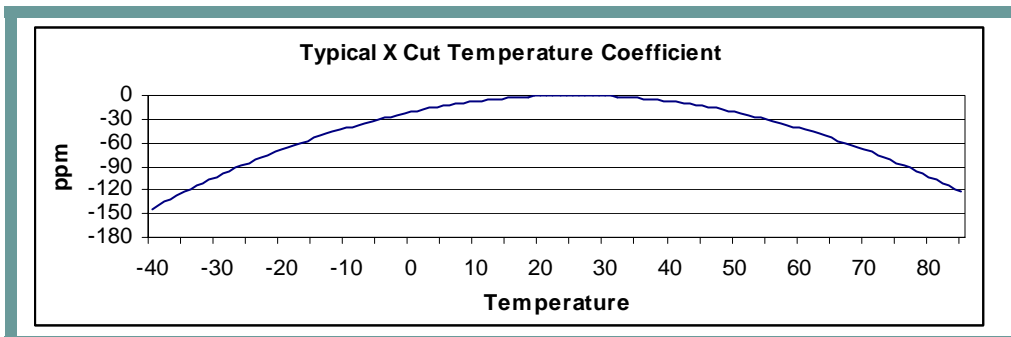
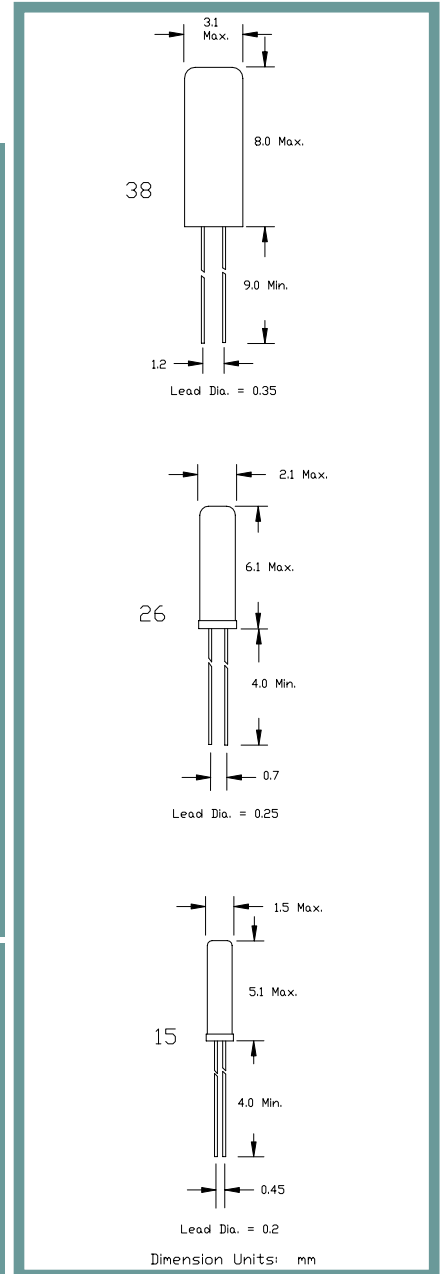

Part Number Guide		Sample Part Number: 26-HX1F12.5 – 32.768 KHz				
Package	Stability (ppm) at Room Temperature	Stability (ppm) over Operating Temperature	Operating Temperature Range	Mode (overtone)	Load Capacitance (pF)	Frequency
38 - (3 mm X 8 mm)	B = ±50 ppm	X = X Cut	0 = 0°C to +50°C	F = Fundamental	12.5 pF Standard.	- 32.768 KHz
26 - (2 mm X 6 mm)	F = ±30 ppm		1 = 0°C to +70°C			
	G = ±25 ppm		2 = -10°C to +60°C			
15 - (1 mm X 5 mm)	H = ±20 ppm		3 = -20°C to +70°C			
	I = ±15 ppm		5 = -40°C to +85°C			
	J = ±10 ppm		9 = -10°C to +50°C			

ILSI America Phone: 775-851-8880 • Fax: 775-851-8882 • e-mail: e-mail@ilsiamerica.com • www.ilsiamerica.com
 Specifications subject to change without notice



2 Lead Metal Package Crystal, 3 mm x 8 mm, 2 mm x 6 mm, 1 mm x 5 mm

38 / 26 / 15 Series

Pb Free Solder Reflow Profile:

Typical Circuit:

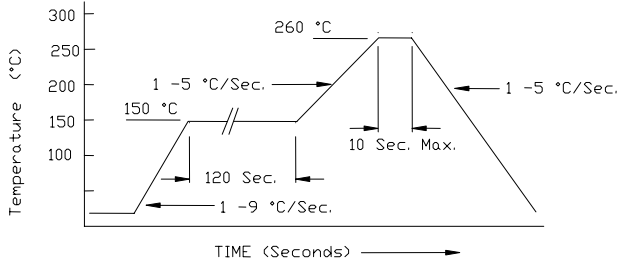

*Units are backward compatible with 240C reflow processes

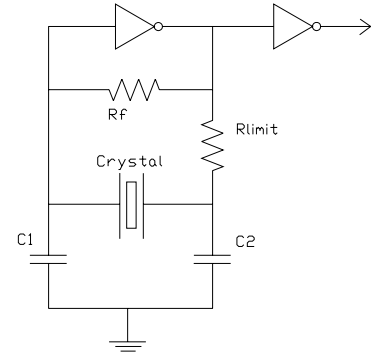

Package Information:

MSL = 2a
Termination = e1 (Sn / Cu / Ag over Ni over Kovar base metal).

Environmental Specifications

Thermal Shock	MIL-STD-883, Method 1011, Condition A
Moisture Resistance	MIL-STD-883, Method 1004
Mechanical Shock	MIL-STD-883, Method 2002, Condition B
Mechanical Vibration	MIL-STD-883, Method 2007, Condition A
Resistance to Soldering Heat	J-STD-020C, Table 5-2 Pb-free devices (except 2 cycles max)
Hazardous Substance	Pb-Free / RoHS / Green Compliant
Solderability	JESD22-B102-D Method 2 (Preconditioning E)
Terminal Strength	MIL-STD-883, Method 2004, Test Condition D
Gross Leak	MIL-STD-883, Method 1014, Condition C
Fine Leak	MIL-STD-883, Method 1014, Condition A2, R1=2x10-8 atm cc/s
Solvent Resistance	MIL-STD-202, Method 215

Marking

N/A –Packaging only