



4 Pad Ceramic Package Quartz Crystal, 3.2 mm x 5 mm



ILCX07 Series

Product Features:

- Low Cost SMD Package
- Low ESR
- Compatible with Leadfree Processing

Applications:

- Fibre Channel
- Server & Storage
- Sonet /SDH
- 802.11 / Wifi
- T1/E1, T3/E3

Frequency	10 MHz to 100 MHz
ESR (Equivalent Series Resistance)	
10 MHz – 13.9 MHz	100 Ω Max.
14 MHz – 19.9 MHz	80 Ω Max.
20 MHz – 39.9 MHz	60 Ω Max.
40 MHz – 66 MHz	40 Ω Max.
30.0 MHz – 100.0 MHz (3 rd O.T.)	100 Ω Max.
Shunt Capacitance (C0)	7 pF Max.
Frequency Tolerance @ 25° C	±30 ppm Standard (see Part Number Guide for more options)
Frequency Stability over Temperature	±50 ppm Standard (see Part Number Guide for more options)
Crystal Cut	AT Cut
Load Capacitance	18 pF Standard (see Part Number Guide for more options)
Drive Level	500 uW Max.
Aging	±5 ppm Max. / Year Standard
Temperature	
Operating	0° C to +70° C Standard (see Part Number Guide for more options)
Storage	-40° C to +85° C Standard

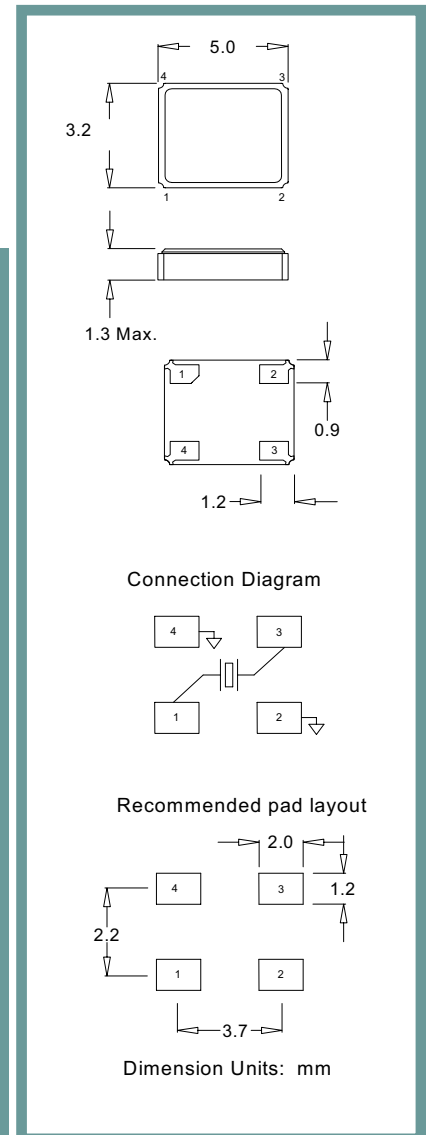

Part Number Guide		Sample Part Number: ILCX07 - FB1F18 - 20.000				
Package	Tolerance (ppm) at Room Temperature	Stability (ppm) over Operating Temperature	Operating Temperature Range	Mode (overtone)	Load Capacitance (pF)	Frequency
ILCX07 -	B = ±50 ppm	B = ±50 ppm	0 = 0°C to +50°C	F = Fundamental	18 pF Standard Or Specify	- 20.000 MHz
	F = ±30 ppm	F = ±30 ppm	1 = 0°C to +70°C	3 = 3 rd overtone		
	G = ±25 ppm	G = ±25 ppm	2 = -10°C to +60°C			
	H = ±20 ppm	H = ±20 ppm	3 = -20°C to +70°C			
	I = ±15 ppm	I = ±15 ppm**	5 = -40°C to +85°C			
	J = ±10 ppm*	J = ±10 ppm**	9 = -10°C to +50°C			

* Not available at all frequencies. ** Not available for all temperature ranges.



4 Pad Ceramic Package Quartz Crystal, 3.2 mm x 5 mm



ILCX07 Series

Pb Free Solder Reflow Profile:

Typical Circuit:

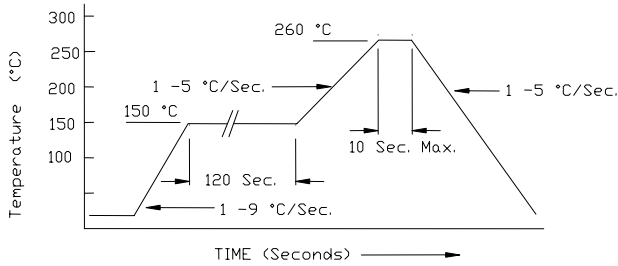

*Units are backward compatible with 240C reflow processes

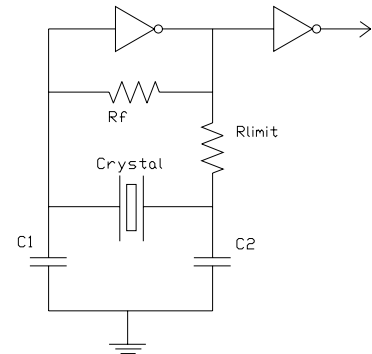

Package Information:

MSL = 1
Termination = e4 (Au over Ni over W base metal).

Tape and Reel Information:

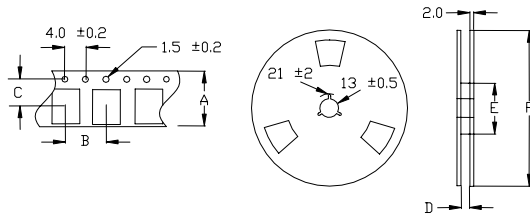

Quantity per Reel	1000
A	12 +/- .3
B	8 +/- .2
C	5.5 +/- .2
D	13.5 +/- 1 or 12 +/- 3
E	60 / 80
F	180 / 250

Environmental Specifications

Thermal Shock	MIL-STD-883, Method 1011, Condition A
Moisture Resistance	MIL-STD-883, Method 1004
Mechanical Shock	MIL-STD-883, Method 2002, Condition B
Mechanical Vibration	MIL-STD-883, Method 2007, Condition A
Resistance to Soldering Heat	J-STD-020C, Table 5-2 Pb-free devices (except 2 cycles max)
Hazardous Substance	Pb-Free / RoHS / Green Compliant
Solderability	JESD22-B102-D Method 2 (Preconditioning E)
Terminal Strength	MIL-STD-883, Method 2004, Test Condition D
Gross Leak	MIL-STD-883, Method 1014, Condition C
Fine Leak	MIL-STD-883, Method 1014, Condition A2, R1=2x10 ⁻⁸ atm cc/s
Solvent Resistance	MIL-STD-202, Method 215

Marking

Line 1: ILSI, Date Code (yww)
Line 2: Frequency