

## Oscillator terms and application notes

**Method 3: Parallel AC termination (Fig. 11)** In parallel AC termination, a R-C combination is placed at the load. The value of the capacitor must be chosen carefully, usually smaller than the 50 pF. This termination is not recommended because it will degrade the rise and fall time of the clock, although it draws no DC current.

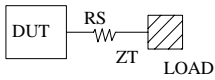

Figure 9

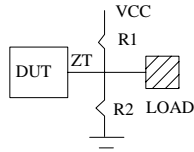

Figure 10

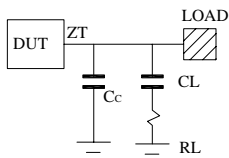

Figure 11

### VOLTAGE CONTROLLED CRYSTAL OSCILLATOR (VCXO)

VCXO is a voltage-controlled crystal oscillator. A VCXO has a voltage-variable (varactor) attached in series with the crystal (figure 12 and 13). By varying the control voltage, the capacitance of the varactor changes accordingly, thus forces the frequency changed.

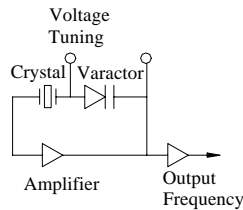

Figure 12

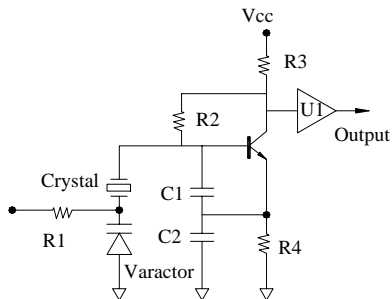

Figure 13

### TEMPERATURE COMPENSATED CRYSTAL OSCILLATORS (TCXOs)

A temperature-compensated crystal oscillator is a crystal oscillator with a temperature-compensated network. The network consists of at least two (2) thermistors (temperature-variable resistors). The thermistors, which are selected during testing for temperature coefficient and values, are used to steer the control voltage in order to compensate the change in frequency over temperature. Temperature compensation can be achieved with or without use of a varactor, however this technique is harder to accomplish because exact resistors values have to be used to compensate. Figure 14 shows a typical TCXO circuit with a thermistor network.

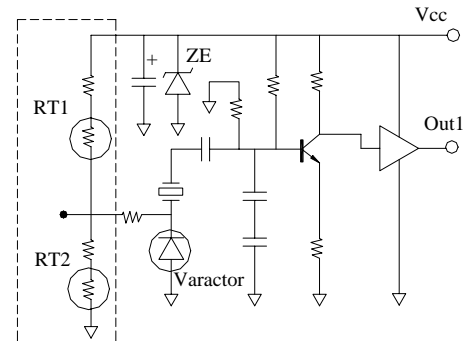

Figure 14

### TCXO APPLICATIONS

**Frequency Stability:** Can achieve  $\pm 0.5$  ppm to  $\pm 3$  ppm. Wide temperature ranges are available. Used widely in various communications equipment (cell phones, cordless phones, etc.), reference clocks, phase-locked loops (PLLs), signal tracking, aerospace, and instrumentation.

External trimmer (mechanical) allows to compensate frequency shift due to aging ( $\pm 1$  ppm max. per year).

Voltage-controlled (analog) or digital TCXO (digital data) can be used to correct frequency shift.